

# Geräte-Verbindungsdose ECON® Iso + für Holzfaser-Dämmplatten

One-gang junction box ECON® Iso + for wood fibre insulation boards / Boîte de jonction ECON® Iso + pour panneaux isolants en fibre de bois / Verdeeldoos ECON® Iso + voor houtvezelisolatiepanelen / Scatola di derivazione ECON® Iso+ per pannelli isolanti in fibra di legno.

## Montageanleitung

Assembly instructions / Instructions de montage / Montage instructies / Istruzioni per il montaggio

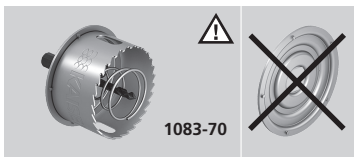
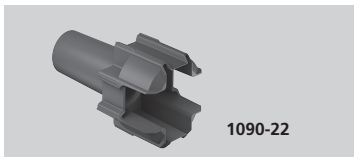

- DE** Montage nur durch in der Elektrotechnik ausgebildete Installateure! Liegen keine entsprechenden Fachkenntnisse vor, so kann es zu einer unsachgemäßen Montage kommen, die die Sicherheit des Produktnutzers gefährdet.
- EN** Installation should be performed only by trained electricians! If no suitable professional staff are available installation may be performed incorrectly, putting the safety of users at risk.
- FR** Seuls des installateurs ayant suivi une formation d'électrotechnicien sont autorisés à effectuer le montage! Si le montage est effectué par un collaborateur ne disposant pas des connaissances spécifiques, l'installation risque d'être non conforme et d'entraîner des risques pour la sécurité de l'utilisateur.
- NL** De montage dient uitsluitend door installateurs met voldoende elektrotechnische kennis te worden uitgevoerd. Onvoldoende vakkundigheid kan tot onjuiste montage leiden die de veiligheid van de gebruikers in gevaar kan brengen.
- IT** Montaggio esclusivamente da parte di specialisti qualificati. Nel caso che il montaggio sia effettuato da un collaboratore senza formazione adeguata, l'installazione può essere difettosa e causare danni all'utente.

## KAISER GmbH & Co. KG

Ramsloh 4 · 58579 Schalksmühle  
DEUTSCHLAND

Tel. +49 (0)23 55/809-61 · Fax +49 (0)23 55/809-21

[www.kaiser-elektro.de](http://www.kaiser-elektro.de) · [technik@kaiser-elektro.de](mailto:technik@kaiser-elektro.de)

 **KAISER**  
GROUP

**Montage in verputzter Dämmplatte bei vorhandener Leitung bzw. Rohr** / Installation in plastered insulation board with existing cable or conduit / Installation dans un panneau isolant plâtré avec câble ou tuyau existant / Installatie in gepleisterde isolatieplaat met bestaande kabel of buis / Montaggio in pannelli isolanti intonacati in caso di conduttori o tubi esistenti

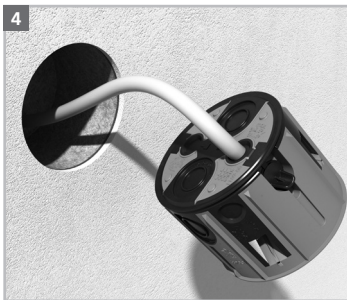
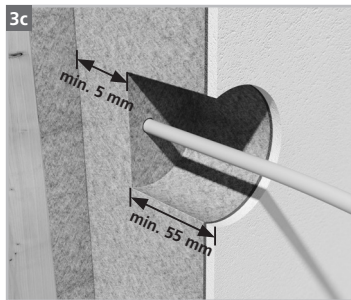
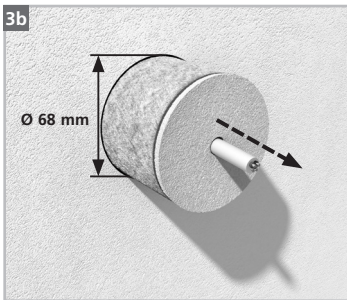
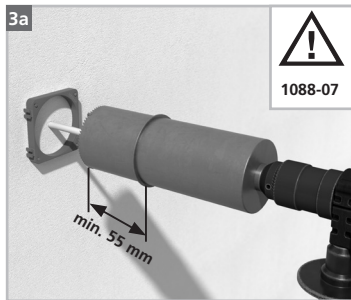

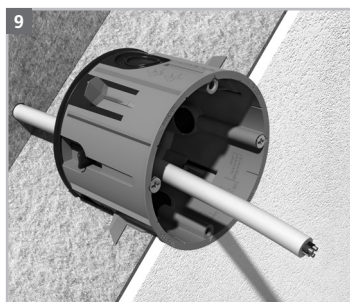
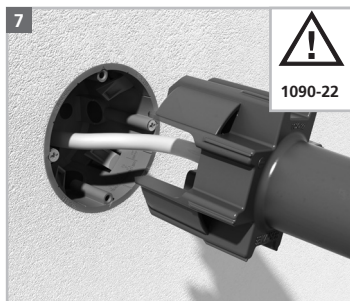
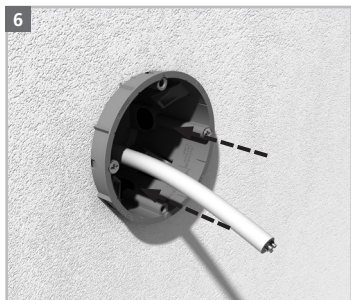

**Montage in unverputzter Dämmplatte ohne Leitung bzw. Rohr** / Installation in unplastered insulation board without cable or conduit / Installation dans un panneau isolant non plâtré sans câble ni tuyau / Installatie in ongepleisterde isolatieplaat zonder kabel of buis / Montaggio in pannelli isolanti non intonacati senza conduttori o tubi

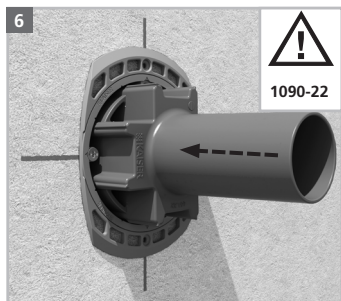
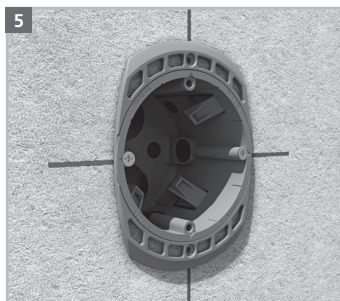
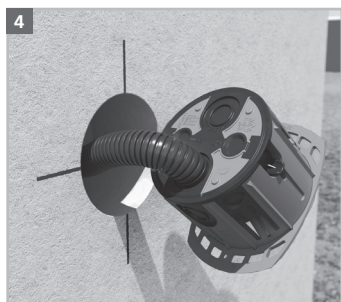
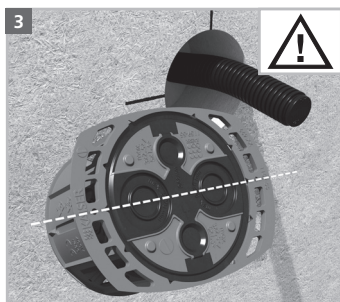
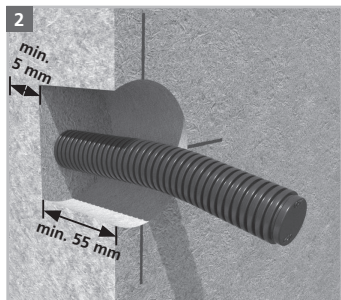
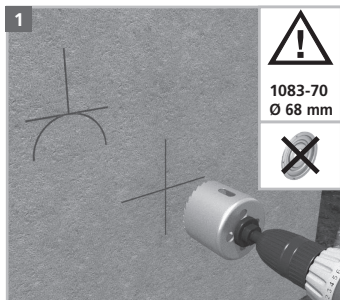

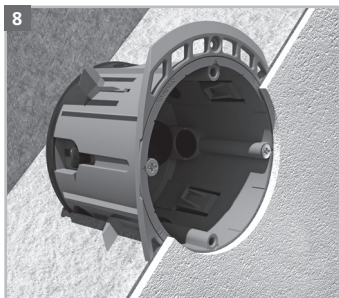
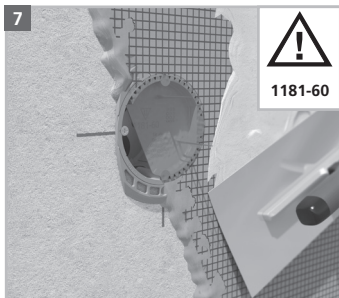

**Mehrfachinstallation** / Multiple boxes / Installation de combinaisons de boîtes /  
Meervoudige installatie / Installazione di combinazioni di scatole

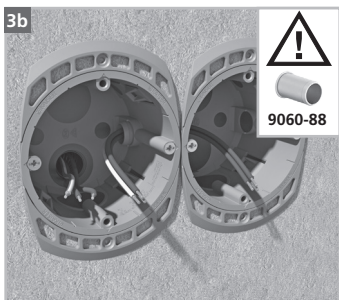
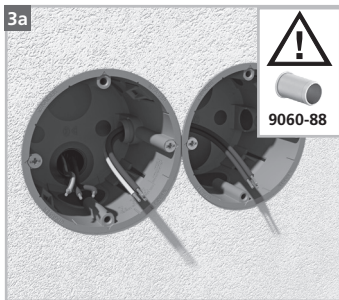
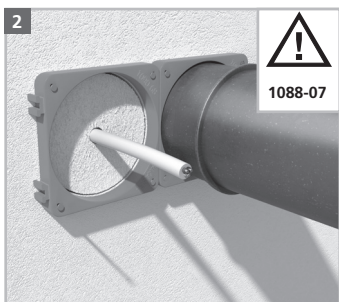

**Demontage / Dismantling / Démontage /  
Demontage / Smontaggio**

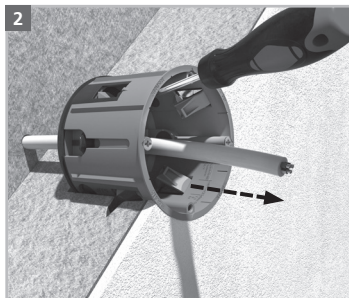

**Technische Spezifikationen / Technical specifications / Spécifications techniques /  
Technische specificaties / Specificazioni tecniche**

mind. Dämmstärke / min. insulation thickness / min. épaisseur isolation / min. isolatiedikte / spessore min. dell'isolazione	<b>60 mm</b>
geeignete Rohdichten / appropriate gross densities / densités appropriées / geschikte dichtheden / densità adatte	<b>110 - 180 kg/m<sup>3</sup></b>
Fräsloch Ø / Cut hole Ø / Trou de fraisage Ø / Freesgat Ø / foro Ø	<b>68 mm</b>
mind. Fräslöchentiefe / min. cut hole depth / min. prof. trou de fraisage / min. freesgatdiepte / profondità min. del foro	<b>55 mm</b>
Rohreinführungen bis M20 / Conduit entries up to M20 / Entrée de tubes jusqu'à M20 / Buisinvoeren tot M20 / Entrate per tubi fino a M20	<b>4</b>
Leitungseinführungen bis Ø 11 mm / Cable entries up to 11 mm Ø / Entrées pour câbles jusqu'à Ø 11 mm / Kabelinvoeren tot Ø 11 mm / Entrate per cavi fino a Ø 11 mm	<b>4</b>



Montagevideo / Installation video /  
Vidéo d'installation / Installatievideo /  
Filmato di installazione

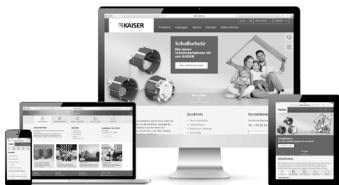

**www.kaiser-elektro.de**